



DESIGN STANDARD COMMUNICATIONS

Mar 29, 2013 RevA

Japan Aerospace Exploration Agency

This is an English translation of JERG-2-400A. Whenever there is anything ambiguous in this document, the original document (the Japanese version) shall be used to clarify the intent of the requirement.

Disclaimer

The information contained herein is for general informational purposes only. JAXA makes no warranty, express or implied, including as to the accuracy, usefulness or timeliness of any information herein. JAXA will not be liable for any losses relating to the use of the information.

Published by

Japan Aerospace Exploration Agency

Safety and Mission Assurance Department

2-1-1 Sengen Tsukuba-shi, Ibaraki 305-8505, Japan

Contents

1. SCOPE.....	1
2. RELATED DOCUMENTS.....	2
2.1 Applicable documents.....	2
2.1.1 CCSDS Recommendations	2
2.1.2 JAXA documents	3
2.2 References	3
3. DEFINITIONS OF TERMS AND ABBREVIATIONS.....	4
3.1 Definitions of terms	4
3.2 Abbreviations	8
4. COMMUNICATIONS OVERVIEW.....	9
4.1 Background	9
4.2 Architecture.....	11
4.2.1 Space communication system.....	11
4.2.2 Ground subnetwork	12
4.2.3 Space link subnetwork	12
4.2.4 Onboard subnetwork	13
4.2.5 Protocol architecture.....	13
5. REQUIREMENTS.....	16
5.1 General requirements.....	16
5.2 Standard protocol.....	16
5.3 Ground subnetwork protocol.....	17
5.4 Space link subnetwork protocol.....	18
5.4.1 Physical layer	19
5.4.2 Telecommand synchronization and channel coding sublayer.....	19
5.4.3 Telecommand data link protocol sublayer.....	19
5.4.4 Telemetry synchronization and channel coding sublayer	20
5.4.5 Telemetry data link protocol sublayer.....	20
5.5 Onboard subnetwork protocol	21
5.5.1 Protocol architecture.....	21
5.5.2 Data link	22
5.5.3 Service	22
5.6 End-to-end protocol.....	23

1 6. VERIFICATION REQUIREMENTS.....	24
6.1 Verification types and purpose.....	24
6.2 Subsystem/payload compatibility test.....	24
6.3 RF compatibility test.....	25
6.4 End-to-end test	26

1. SCOPE

This Communications Design Standard (called the “Design Standard” hereinafter) specifies the basic requirements for communications design for remote information transmission by an end-to-end space communication system.

Information-related requirements are specified by other standards (JERG-2-700 Operation Design Standard) and are not treated in this standard.

2. RELATED DOCUMENTS

2.1 Applicable documents

The documents below are applied within the scope referred to in this Design Standard and, if there is a discrepancy, this Design Standard has priority unless otherwise specified.

2.1.1 CCSDS Recommendations

- (1) CCSDS 131.0-B-2 (Issue 2. August 2011)
TM Synchronization and Channel Coding
- (2) CCSDS 133.0-B-1 (Issue 1. September 2003)
Space Packet Protocol
- (3) CCSDS 135.0-B-4 (Issue 4. October 2009)
Space Link Identifiers
- (4) CCSDS 231.0-B-2 (Issue 2. September 2010)
TC Synchronization and Channel Coding
- (5) CCSDS 232.0-B-2 (Issue 2. September 2010)
TC Space Data Link Protocol
- (6) CCSDS 232.1-B-2 (Issue 2. September 2010)
Communications Operation Procedure-1
- (7) CCSDS 401.0-B-21 (Issue 21. July 2011)
Radio Frequency and Modulation Systems – Part 1: Earth Stations and Spacecraft
- (8) CCSDS 732.0-B-2 (Issue 2. July 2006)
AOS Space Data Link Protocol
- (9) CCSDS 910.4-B-2 (Issue 2. October 2005)
Cross Support Reference Model – Part 1: Space Link Extension Service
- (10) CCSDS 911.1-B-3 (Issue 3. January 2010)
Space Link Extension – Return All Frames Service Specification
- (11) CCSDS 911.5-B-2 (Issue 2. January 2010)
Space Link Extension – Return Operational Control Fields Service Specification
- (12) CCSDS 912.1-B-3 (Issue 3. July 2010)
Space Link Extension – Forward and CLTU Service Specification

2.1.2 JAXA documents

- (1) JERG-2-420
RF Telecommunications Link Design Standard
- (2) MAS-120001 NC
Tracking Control System Telemetry and Telecommand Interface Conditions
- (3) OSO 500-1.1
DIOSA Interface Specification: Space Data Transfer Protocol (SDTP) (Common specifications)
- (4) OSO 501-3.1
DIOSA Interface Specification: Space Data Transfer Protocol (SDTP) (Individual specifications)

2.2 References

- (1) JERG-2-700
Spacecraft Operation Design Standard

3. DEFINITIONS OF TERMS AND ABBREVIATIONS

3.1 Definitions of terms

The definitions of terms related to this Design Standard are shown below.

(1) ARQ (Automatic Repeat reQuest)

A mechanism that, when the receiving side detects a transmission error, automatically requests the sender to retransmit.

(2) HK (housekeeping) data

Data indicating the condition or status of onboard equipment (payload and subsystem).

(3) Architecture

The term architecture used in this Design Standard refers to the design concept or configuration of space communication systems.

(4) Internet protocol

At present, the protocol to connect multiple networks is the TCP/IP protocol suite as a de facto standard. As such, the term "Internet protocol" is generally referred to as IP of the TCP/IP protocol suite.

In this Design Standard, the Internet protocol means IP (Internet Protocol) of the TCP/IP protocol suite.

(5) End-to-end protocol

The protocol, used for space communications, to connect multiple networks (onboard subnetwork, space link subnetwork, and ground subnetwork) including the spacecraft network.

The ground subnetwork takes a configuration in which an end-to-end protocol exists on top of IP of the TCP/IP protocol suite.

In this Design Standard, the protocol applied as an end-to-end protocol is the CCSDS space packet protocol.

(6) Octet

A unit of data length. A data set separated by 8 bits is called "octet" (8 bits × N data is N data octets). The minimum data transmission unit in this Design Standard is 1 octet.

(7) Onboard data link

The interface used in onboard subnetworks and serving the functions of the bottom two layers of the OSI reference model. Includes MIL-STD-1553B, SpaceWire, etc.

- (8) Command
The instruction to a spacecraft.
- (9) Service
The functionality of a certain layer (N layer) and the layers below it, provided to the (N+1) layer at the boundary between that layer (N layer) and the (N+1) layer.
- (10) Subnetwork
An open system that has the relay function and can establish a network connection. A space communication system consists of the three subnetworks of onboard subnetwork, space link subnetwork and ground subnetwork.
- (11) Simplex
One-way communication from a data source (data transmission source) to data destination (data transmission target).
- (12) Time stamp
Time data added to the information to indicate the time of occurrence of the information. A telemetry packet adds the time of occurrence of the packet in the secondary header.
- (13) Channel coding
Refers to the data sending side adding an error detection code or an error correction code to the information and the receiving side doing transmission error detection and correction in order to ensure data transmission quality against the noise on the transmission line
- (14) Telecommand
tele (telecommunication) + command. Telecommunication of commands (from the ground to a spacecraft)
- (15) Telemetry
tele (telecommunication) + metry (measurement). Telecommunication (from a spacecraft to the ground) of metry. Metry means measurement and refers to HK data and payload data.
- (16) Network
Refers to a computer network.
- (17) Node
Refers to the node making up a network. In a space communication system, this corresponds to the payload, subsystems, onboard communications and data processing system, ground station facilities, and ground users.
- (18) Packet
The Packet used in this Design Standard refers to Space Packet defined by the applicable document CCSDS Recommendation (2). It is not an ISO packet. Space Packet is the minimum transmission data unit (variable length) flowing through the space communication system. This Design Standard uses Packet and Space Packet as synonyms.

- (19) Protocol
Refers to a set of procedures, conventions, etc. to transmit data on a network.
- (20) Payload
Refers to the equipment on board the spacecraft that is necessary for a specific purpose (observation instrument, space experiment apparatus, communication equipment, etc.).
- (21) Payload data
Refers to the measurement data, experiment data, etc. acquired by the payload.
- (22) Point-to-point
Refers to communications from one sender to one recipient.
- (23) Point-to-multipoint
Refers to communications from one sender to N recipients.
- (24) Randomization
For the data receiving side to surely acquire and keep bit synchronization, the data is modulated by a PN (Pseudo Noise) code (spread spectrum code having the nature of noise) to ensure the necessary Bit Transition Density (a sequence of alternating ones and zeros gives the maximum transition density).
- (25) Spacecraft operation control
Refers to the function of monitoring and controlling a spacecraft (Spacecraft Monitor & Control)
- (26) Space communication system
Refers to the network made up of multiple subnetworks present between the spacecraft end-user and ground end-user (apparently one network).
- (27) Error detection
Refers to the sending side adding an error detection code to the information and the receiving side detecting a transmission error occurring on the transmission line. If a transmission error is detected, a request for re-transmission is made to the sending side. Used for telecommand.
- (28) Error correction
Refers to the sending side adding an error correction code to the information and the receiving side correcting transmission errors occurring on the transmission line. Used for telemetry.
- (29) Mutual support (cross support)
Refers to the interconnection between different space agencies. Refer to the applicable document CCSDS (9).
- (30) Ground node
Refers to the computer and hardware entities present on the ground and mutually

connected by standard communications protocols.

(31) Communications

Communications used in this Design Standard refers to the mechanism to transmit telemetries and telecommands.

(32) Onboard node

Refers to the computer and hardware entities present in a spacecraft and mutually connected by standard communications protocols.

(33) Logical data path

Refers to the logical path for space packets from one application source to one or multiple application destinations via one or multiple subnetworks. Refer to the applicable document CCSDS Recommendation (2).

3.2 Abbreviations

The abbreviations related to this Design Standard are shown below.

AOS	Advanced Orbiting Systems
ARQ	Automatic Repeat Request
CCSDS	Consultative Committee for Space Data Systems
CLCW	Communications Link Control Word
CLTU	Communications Link Transmission Unit
COP	Communications Operation Procedure
CPU	Central Processing Unit
CRC	Cyclic Redundancy Check
DIOSA	Distributed Operations System Architecture
EMC	Electro-Magnetic Compatibility
HK	House Keeping
ID	Identification
IETF	Internet Engineering Task Force
ISO	International Organization for Standardization
JAXA	Japan Aerospace Exploration Agency
LAN	Local Area Network
LDPC	Low Density Parity Check
MOD	Modulation
OCF	Operational Control Field
OSI	Open System Interconnection
PLOP	Physical Layer Operations Procedure
RAF	Return All Frames
RF	Radio Frequency
RFC	Request for Comment
SDTP	Space Data Transfer Protocol
SDU	Service Data Unit
SEC	Single Error Correction
SLE	Space Link Extension
SM&C	Spacecraft Monitor and Control Protocol
SOIS	Spacecraft Onboard Interface Services
TC	Telecommand
TCP/IP	Transmission Control Protocol/Internet Protocol
TED	Triple Error Detection
TM	Telemetry
VCID	Virtual Channel Identification
WAN	Wide Area Network

4. COMMUNICATIONS OVERVIEW

4.1 Background

Communications means remote transmission of information between a ground end-user and spacecraft end-user (end-to-end).

Information is the commands and HK data for spacecraft operation control, and payload data obtained by the payload. Remote transmission of a command is called "Telecommand" and remote transmission of HK data and payload data is called "Telemetry".

Besides these, spacecraft time calibration information for the ground side to exactly know the spacecraft time is also transmitted. This is classified as a Telecommand or Telemetry from the viewpoint of transmission.

Requirements for Telecommand and for Telemetry are different.

For Telecommand, no transmission error is basically allowed for the purpose of transmitting a command. Therefore, it is general practice that the receiving side (spacecraft) does error detection and makes a repeat request to the sending side (ground side) if an error is detected. In addition, it is also required to surely keep the transmission sequence.

Because Telemetry involves transmission of HK data and payload data, it is given priority to transmit a large amount of data. Therefore, it is general practice that the receiving side (ground side) does error correction only.

Telecommand and Telemetry formerly used the multiplex method of TDM (Time Division Multiplex); however, technical limitations and increases in time and cost of development, operation, maintenance, etc. gave rise to an issue common to the space agencies of the world. At present, the packet method recommended by CCSDS (Consultative Committee for Space Data Systems) inaugurated in 1982 is used by space agencies, etc. of the world. The CCSDS recommendations are all the international standards established as an ISO (International Organization for Standardization) standard.

The space communications according to the CCSDS recommendations is an extension to outer space of the OSI (Open System Interconnection) reference model which makes the base of the protocol established in 1977 by ISO to connect multiple networks. Figure 4.1-1 shows the layers of the OSI reference model and the layers of CCSDS space communications. JAXA uses only space packets for end-to-end communications and does not use the application layer and transport layer. The recommendation defines the services of each layer and specifies their protocol.

The CCSDS Space Communications Recommendation consists of the three subnetworks (onboard subnetwork, space link subnetwork, and ground subnetwork) between the ground

and a spacecraft and the end-to-end protocol to connect them each other.

Layers of OSI reference model		Layers of CCSDS	
7th layer	Application Layer	Application Layer	
6th layer	Presentation Layer		
5th layer	Session Layer		
4th layer	Transport Layer	Transport Layer	
3rd layer	Network Layer	Network Layer	
2nd layer	Data Link Layer	Data Link Layer	Data Link Protocol Sublayer
			Sync. and Channel Coding Sublayer
1st layer	Physical Layer	Physical Layer	

Figure 4.1-1 Layers of OSI Reference Model and CCSDS Recommendation for Space Communications

Besides this, there are the SLE (Space Link Extension) recommendation for mutually supporting and connecting ground facilities and the SOIS (Spacecraft Onboard Interface Services) specifying the services of onboard subnetworks.

JAXA has so far developed spacecraft according to the CCSDS recommendations.

Including the above, communications standardization takes place to realize the following.

- For the communications user, onboard equipment, test equipment, written procedures, ground facilities, etc. can be used in the same way even for a different spacecraft (cost and time saving).
- By forming a logical data path between the ground end-user and spacecraft end-user, the user of the communications can transmit data whenever he wants without being affected by other users.
- Mutual support (cross support) is possible (expansion of the network, support at an emergency of the spacecraft, etc., and cost and time saving in coordination work).
- Ensuring availability, ensuring reliability and safety, and considering cost effectiveness.

4.2 Architecture

4.2.1 Space communication system

The general configuration (major communication nodes and connections) of a space communication system is shown in Figures 4.2.1-1 and 4.2.1-2. Figure 4.2.1-1 is a configuration diagram focusing on the physical configuration and Figure 4.2.1-2 is a configuration diagram focusing on the network.

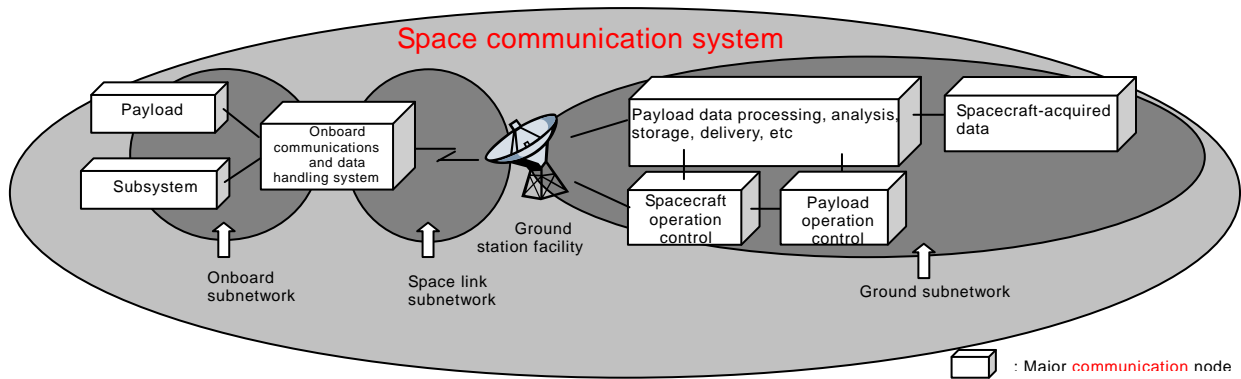
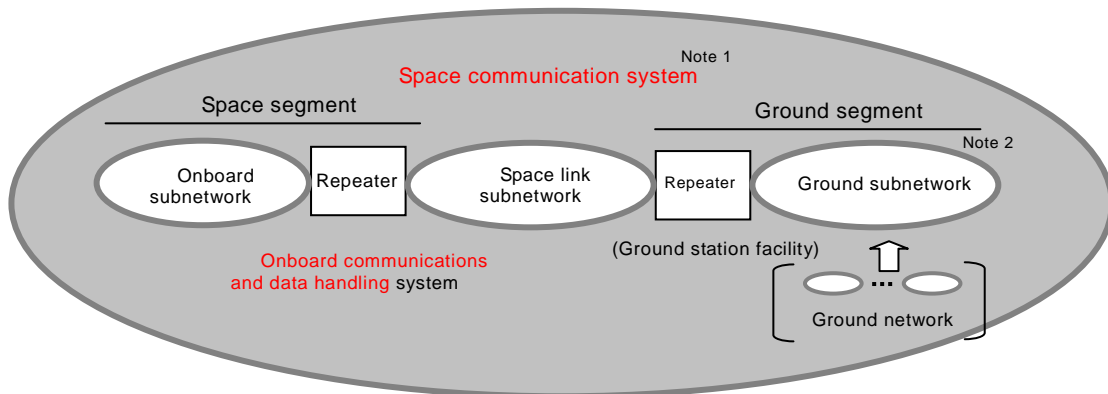

Figure 4.2.1-1 General configuration focusing on physical configuration



Note 1: One network formed by multiple subnetworks connected by an end-to-end protocol.

Note 2: The ground subnetwork is an Internet network formed by multiple ground networks connected by an Internet protocol.

Figure 4.2.1-2 General configuration focusing on network

Space communications consist of many different networks which can be classified into ground network, ground-spacecraft network and spacecraft network as shown in Figure 4.2.1-1. Each network classified is a subnetwork.

- (1) Ground subnetwork: Connection between ground nodes such as a ground station facility, spacecraft operation control, payload operation control, payload data processing, user institute, etc.
- (2) Space link subnetwork: Connection between ground node and spacecraft node.
- (3) Onboard subnetwork: Connection between onboard nodes such as an onboard communications and data processing system, payload, and subsystem.

These three different subnetworks are connected by an end-to-end protocol to make one network. This network is called a space communication system.

4.2.2 Ground subnetwork

The ground subnetwork is a network with nodes of communications for operation control of the spacecraft, operation control of the payload, processing of data acquired by the payload (data processing, analysis, archiving, delivery, etc.) and the user institute. One node on this network is a ground station (repeater).

A ground subnetwork generally consists of multiple different networks. These multiple different networks are generally connected by IP of the TCP/IP protocol suite.

On this ground subnetwork, an end-to-end protocol functions.

In addition, a ground subnetwork needs a standard protocol (SLE, etc.) for efficient transmission and reception of packets, etc. between nodes in the ground subnetwork.

4.2.3 Space link subnetwork

The link to connect a repeater (ground station facility) of the ground subnetwork and a node repeater (onboard communications and data processing system) of the onboard subnetwork.

This link is a radio link made of two simplexes (transmission from spacecraft to ground and transmission from ground to spacecraft). The radio link from a spacecraft to the ground is called a downlink (or a return link), and the radio link from the ground to a spacecraft is called an uplink (or a forward link). A downlink transmits telemetries and an uplink transmits telecommands. The reason for taking simplexes is there is the need to monitor the satellite even if there is no uplink and there is the need to transmit commands even if there is no

downlink.

Telecommand transmission has ARQ (automatic repeat request) or another mechanism to maintain data integrity; however, a repeat request is transmitted through another simplex (downlink). In preparation for spacecraft or link abnormalities, the telecommand transmission must be able to take place even if there is no downlink (ARQ not available), and this is a requirement.

Connection takes place in the form of point-to-point or point to multipoint.

There are cases where a relay satellite intervenes between the ground station facility and the onboard communications and data processing system. In such a case, the relay satellite functions as a repeater (signal regeneration or relay supported only by the physical layer).

Because the space link subnetwork is a radio link of great distance, its link quality is inferior to a ground subnetwork or onboard subnetwork. Therefore, it needs a special channel coding or transmission procedure.

4.2.4 Onboard subnetwork

The onboard subnetwork is a network within the spacecraft with its subsystems and payload being nodes of communications. One node on this network is the onboard communications and data processing system (repeater).

The number of onboard subnetworks is not limited to one either, and there are cases where a subnetwork is in turn made up of multiple subnetworks. If there are multiple subnetworks, they are connected by repeaters.

4.2.5 Protocol architecture

As shown in Figure 4.2.6-1, a space communication system is made up nodes connected by a standard protocol.

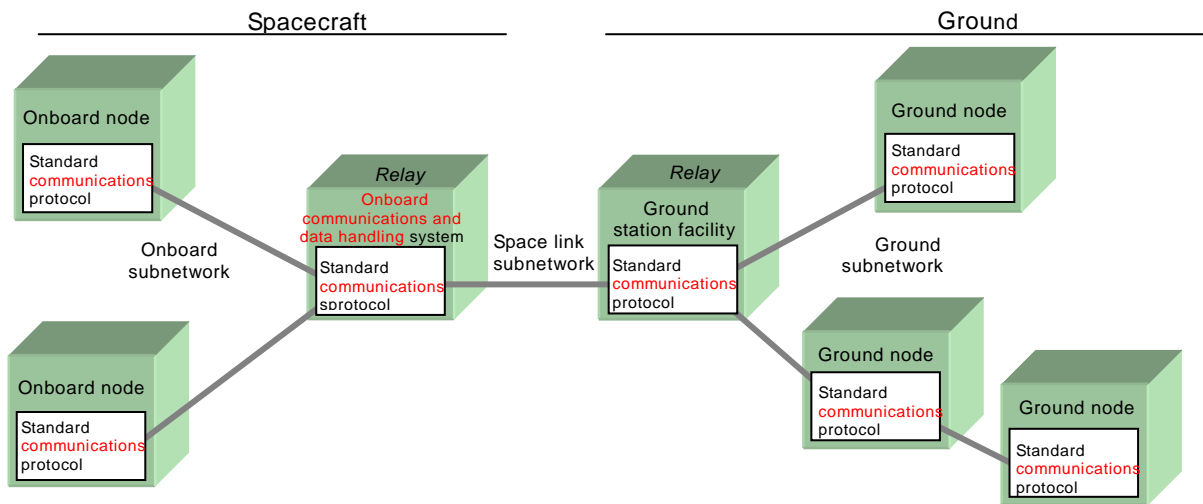

Figure 4.2.6-1 Space Communication System Architecture

If modeled, Figure 4.2.6-1 can be represented by four nodes as shown in Figure 4.2.6-2.

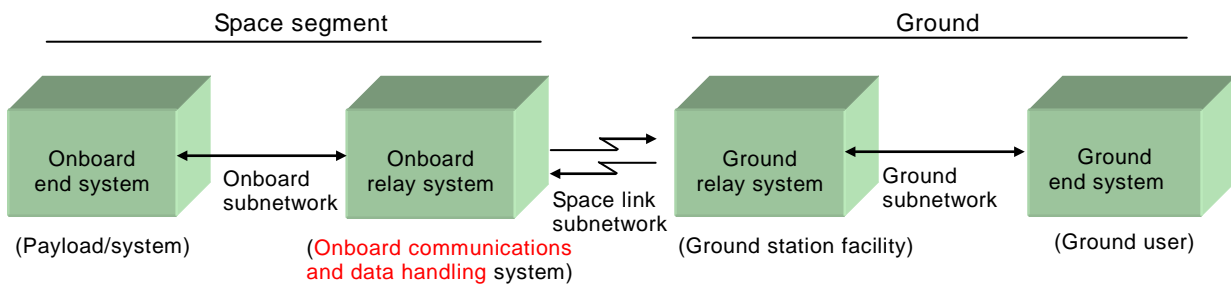

Figure 4.2.6-2 Model of Space Communication System

Figure 4.2.6-2, if described based on communications protocols according to the OSI reference model, becomes a diagram as shown in Figure 4.2.6-3.

In Figure 4.2.6-3, the higher protocol is for operation (Spacecraft Monitor and Control Protocol: SM&C), and it is specified in reference document (1).

This Communications Design Standard provides the following four standard protocols as shown in Figure 4.2.6-3.

- Ground subnetwork protocol
- Space link subnetwork protocol
- Onboard subnetwork protocol
- End-to-end protocol

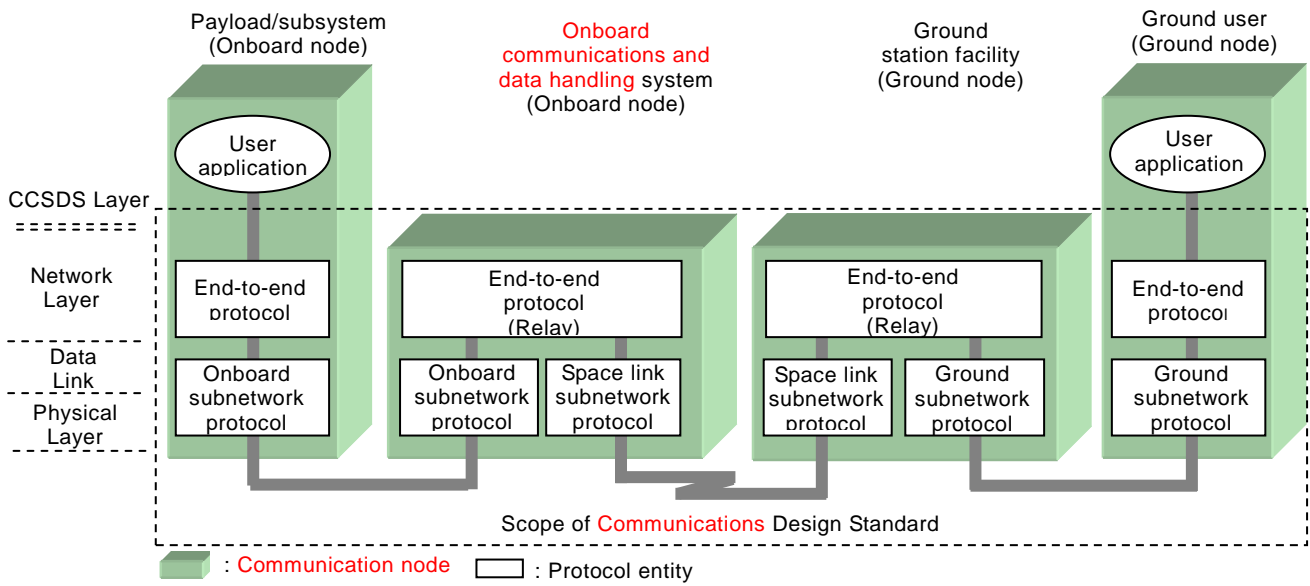

Figure 4.2.6-3 Communications Protocol Architecture of Space Communication System

5. REQUIREMENTS

5.1 General requirements

- (1) Considering a spacecraft attitude abnormality and other kind of abnormality, the telemetry and telecommand transmission shall be ensured the required transmission link quality.
- (2) Transmitted data includes the event trigger type (command, upload/download data, etc.) and the time trigger type (HK data, etc.). It shall be transmitted these data with high efficiency.
- (3) A telemetry packet generated in the spacecraft shall have a time stamp of the data acquisition time.
- (4) A telemetry link and command link are not always established. At an occurrence of a spacecraft abnormality, etc., the communications shall take place even with either link alone.
- (5) If so required, it shall be possible to change over the type or frequency of occurrence of telemetry to be transmitted or accumulate telemetry data and transmit such data afterwards according to the operation mode or communications link condition.

5.2 Standard protocol

The protocols to be applied in this Communications Design Standard are shown in Table 5.2-1.

Table 5.2-1 Standard Protocol

Protocol	Specification name	Specification number	
Ground subnetwork protocol	TCP/IP protocol suite	RFC of IETF.	
	H-II Protocol	MAS-120001 ^{Note 1}	
	Space Data Transfer Protocol (SDTP)	DIOSA OSO500-1.1 ^{Note 2}	
		DIOSA OSO501-3.1 ^{Note 3}	
Space Link Extension (SLE)	CCSDS 910.4-B CCSDS 911.1-B CCSDS 911.5-B CCSDS 912.1-B		
Space link subnetwork protocol	TC	TC Space Data Link Protocol	CCSDS 232.0-B
		Communications Operation Procedure-1 (COP-1)	CCSDS 232.1-B
		TC Sync. and Channel Coding	CCSDS 231.0-B
	TM	AOS Space Data Link Protocol	CCSDS 732.0-B
		TM Sync. and Channel Coding	CCSDS 131.0-B
	RF	RF and Modulation	CCSDS 401.0-B
		RF Communication System Design Standard	JERG-2-410
RF Link Design Standard		JERG-2-420	
Onboard subnetwork protocol	TBD	JERG-2-430s	
End-to-end	Space Packet Protocol	CCSDS 133.0-B	

IETF: Internet Engineering Task Force. RFC: Request for Comment

Note 1: Applicable document 2.1.2(3)

Note 2: Applicable document 2.1.2(4)

Note 3: Applicable document 2.1.2(5)

5.3 Ground subnetwork protocol

- (1) The standard protocols used in a ground subnetwork are shown in Figure 5.3-1. To the networks on the ground, an end-to-end protocol for end-to-end connection between the ground and a spacecraft is applied on the Internet protocols (TCP/IP protocol suite) for connection between ground networks. In addition to these two protocols, the SLE (Space Link Extension) recommendations of CCSDS (applicable documents: CCSDS recommendations (9) to (12)) are applied as a protocol for mutual support (cross support) when sending and receiving packets or frames between ground institutes.
- (2) In regard to application of the SLE recommendation: Before SLE recommendation was established, JAXA had developed and used JAXA-specific H-II protocol (applicable document: JAXA document (3)) and SDTP (Space Data Transfer Protocol) (applicable document: JAXA documents (4) and (5)). To the connection with other institutes, the SLE recommendation is applied as standard; however, between pieces of equipment

within JAXA, the H-II protocol and SDTP are also JAXA standard.

- (3) When applying the SLE recommendation of CCSDS, it shall be applied the RAF service to the telemetry transfer service and the CLTU service to the TeleCommand transfer service.

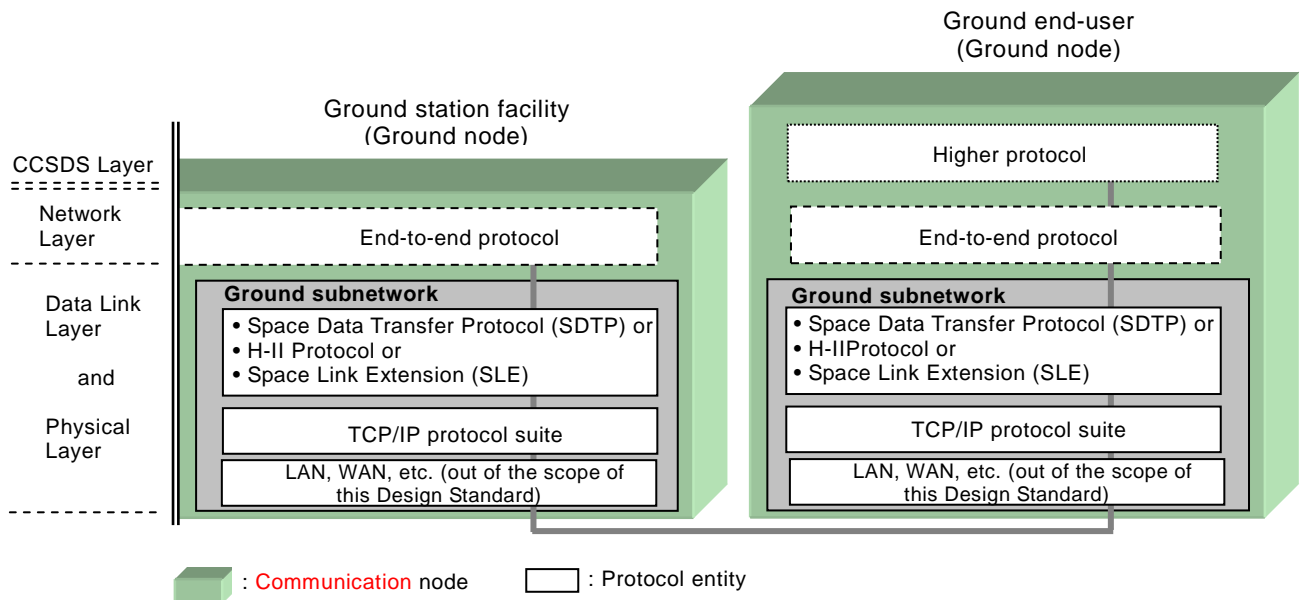

Figure 5.3-1 Architecture and Standard Protocols of Ground Subnetwork

5.4 Space link subnetwork protocol

The standard protocols used on the space link subnetwork are shown in Figure 5.4-1.

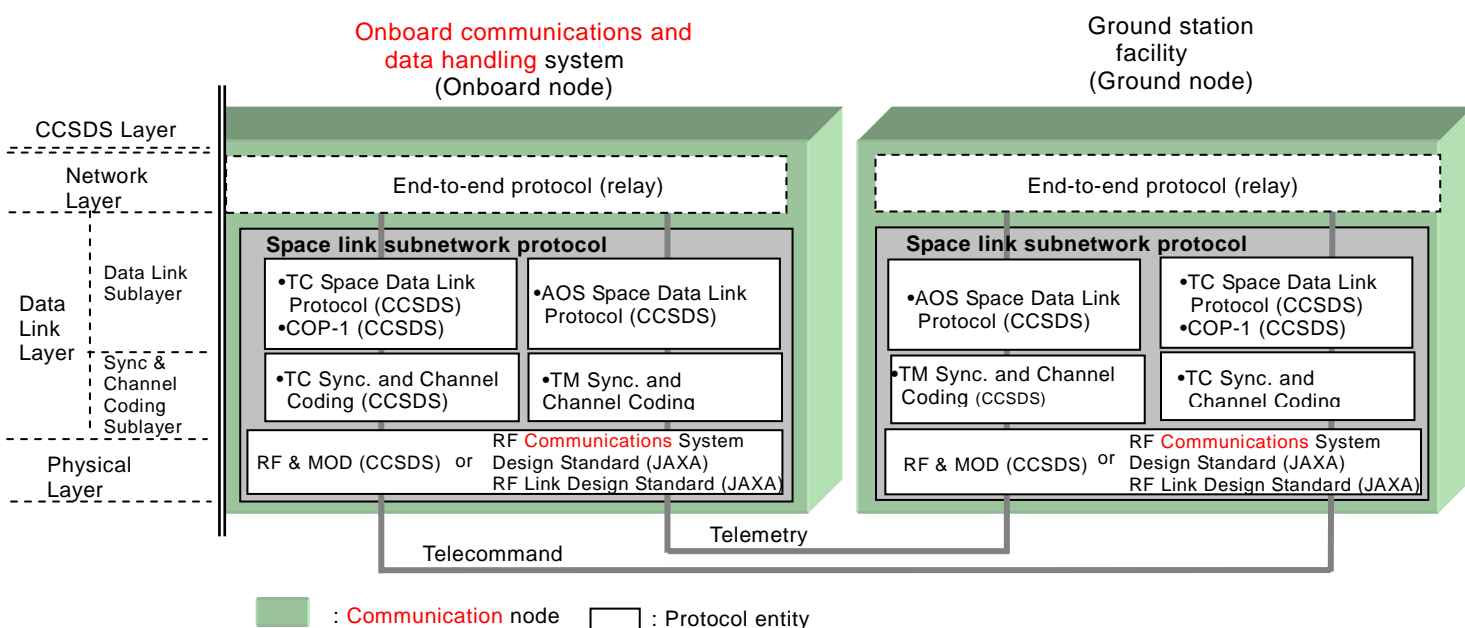

Figure 5.4-1 Architecture and Standard Protocols of Space Link Subnetwork

5.4.1 Physical layer

- (1) RF & Modulation (applicable document: CCSDS Recommendation (7)) of CCSDS, the RF Communications System Design Standard (applicable document: JAXA document (1)) and the RF Link Design Standard (applicable document: JAXA document (1)) shall be applied.

5.4.2 Telecommand synchronization and channel coding sublayer

- (1) CCSDS TC Sync. and Channel Coding (applicable document: CCSDS Recommendation (4)) shall be applied.
- (2) Multiple packets can be transmitted in one CLTU; however, note that the throughput can lower when transmitting multiple packets per CLTU.
- (3) As the decoding mode, the two modes shown in Table 5.4.2-1 are available. These two modes differ in transmission quality (CLTU discard rate, undetected error rate and throughput). For each spacecraft, it shall be made a selection based on the required transmission quality.

Table 5.4.2-1 Decoding mode

Decoding mode	Start sequence detection mode		BCH decoding mode		Frame error control (CRC)
	All bit agreement	1-bit error allowed	TED	SEC	
Error-Detecting	○	---	○	---	No
Error Correcting	---	○	---	○	Yes

TED: Triple Error Detection SEC: Single Error Correction

- (4) Whether or not to apply randomization depends on the bit synchronization characteristics of the command receiver. In general, it is desirable to apply it.
- (5) PLOP (Physical Layer Operations Procedure) includes PLOP1 and PLOP2. PLOP2 shall be used.

5.4.3 Telecommand data link protocol sublayer

- (1) The TC Space Data Link Protocol (applicable document: CCSDS Recommendation (5)) shall be applied.
- (2) There are seven services. Apply them with an understanding of their use. Commonly used services are the Virtual Channel Packet (VCP) service and COP Management service.
- (3) In case of the Error Correcting mode (Table 5.4.2.2-1), the frame error control (CRC) shall be used (otherwise, undetected errors increase).
- (4) VCID shall use 0 or 0 and 1 (in case of changing over the main and subordinate

systems) only.

- (5) For the operation procedure, CCSDS Communications Operation Procedure-1 (COP-1) (applicable document: CCSDS Recommendation (6)) shall be applied.

5.4.4 Telemetry synchronization and channel coding sublayer

- (1) TM Sync. and Channel Coding (applicable document: CCSDS Recommendation (1)) shall be applied.
- (2) The transmission control code is generally used in the combinations shown in Figure 5.4.4-1. Different combinations differ in coding gain. For each spacecraft, make a selection based on the required coding gain.
- (3) Whether or not to apply randomization depends on the bit synchronization characteristics of the telemetry receiver. In general, it is desirable to apply it.

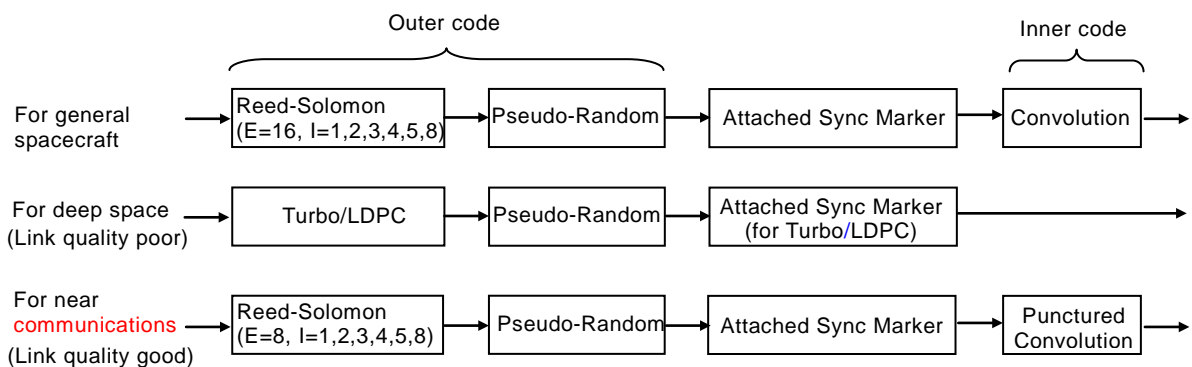

Figure 5.4.4-1 General code usage

5.4.5 Telemetry data link protocol sublayer

- (1) The AOS Space Data Link Protocol (applicable document: CCSDS Recommendation (8)) shall be applied.
- (2) There are seven services. Apply them with an understanding of their use. Commonly used services are the Packet service and Virtual Channel Operational Control Field (VC_OCF) service.
- (3) When transmitting CLCW, CLCW shall be transmitted in VC_OCF (Presence of Operational Control Field).

5.5 Onboard subnetwork protocol

5.5.1 Protocol architecture

The protocol architecture and the protocols of an onboard subnetwork are shown in Figure 5.5-1.

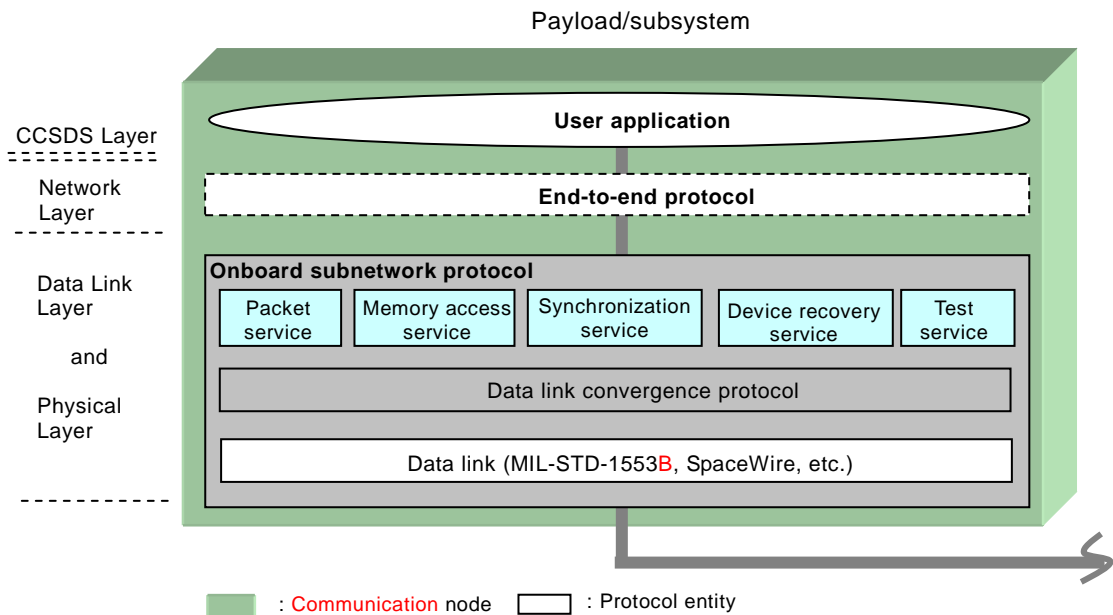

Figure 5.5-1 Architecture of Onboard Subnetwork

A data link of an onboard subnetwork uses the protocol (for example, MIL-STD-1883B, SpaceWire, etc.) with functions corresponding to the bottom two layers of the OSI reference model.

An onboard subnetwork interfaces with an upper application with five standardized services. (Note 1)

The data convergence protocol of an onboard subnetwork is the function for standardizing the services for various data links. A data link is required of the six functions shown in Section 5.5.2; however, all protocols used for a data link do not necessarily provide these six functions. If the protocol used lacks these functions, these are made up for by the data convergence protocol. (Note 2)

Note 1: When an upper application is interfaced with a data link, it is influenced by the protocol used for the data link. Therefore, a standard service independent of the protocol used for the data link has been established.

Note 2: When implementing, the three independent standard protocols (service,

convergence and data link) are not generally used in combination. A protocol for the service (including the convergence function) exists corresponding to the data link. The interface with an upper application is the same even for a different data link.

5.5.2 Data link

The requirements for a data link are the following six functions. It is desirable that all data links satisfy these six requirements.

- (1) Redundant function: The function to transmit data from a source end point to a destination end point in one network through a redundant transmission line. The transmission lines in the main system shall be independent of the transmission lines in the subordinate system.
- (2) Retransmission function: The function of resending data if the transmitted data could not reach the destination because of loss or a transmission error.
- (3) Segmentation function: The function of the sending side dividing and transmitting the data from an upper application and the receiving side joining and the divided data and transmitting the joined data to the upper application. This function is used in the following cases. (a) In the case where the data length of an upper application exceeds the maximum data length that can be transmitted on the data link, and (b) in the case where long data transmission of an upper application causes an unnecessary delay in short data transmission of another upper application.
- (4) Traffic management: In general, one of the following. (a) without transmission band assignment and with the retransmission function, (b) without transmission band assignment and without the retransmission function, (c) with transmission band assignment and without the retransmission function, and (d) with transmission band assignment and with the retransmission function.
- (5) Priority control: The function of transmitting high-priority data preferentially.
- (6) Protocol multiplexing function: The function of multiple networks or an upper layer to access a service of a subnetwork layer by the protocol identification capability unique to the subnetwork.

5.5.3 Service

The services interfacing with an upper application are shown below.

- (1) Packet service: The packet service of an onboard subnetwork transfers packets (octet data (data of a variable length of an integer multiple of 8 bits)) from an end point of the onboard subnetwork to another end point of the same onboard subnetwork.
- (2) Memory access service: The memory access service of an onboard subnetwork reads or writes data from or to a memory in a node of the onboard subnetwork.
- (3) Synchronization service: The synchronization service of an onboard subnetwork synchronizes the time commonly used in subnetworks.
- (4) Device service: The device service of an onboard subnetwork notifies the users in the onboard subnetwork of the presence of a device.
- (5) Test service: The test service of an onboard subnetwork tests the functionality or connectivity of the subnetwork.

5.6 End-to-end protocol

- (1) Apply the Space Packet Protocol (applicable document: CCSDS Recommendation (2)).
- (2) Be sure to enter a time stamp indicating the data acquisition time in the secondary header of the telemetry packet.

[For reference] Outline of Space Packet Service

The space packet protocol transmits space packets from one source user application to one or more destination user applications by unidirectional data transmission through one or more subnetworks. The path of this transmission is called “Logical Data Path (LDP)” and the identifier of this path (Path ID) is called APID (Application Process Identifier). (Figure 5.6-1)

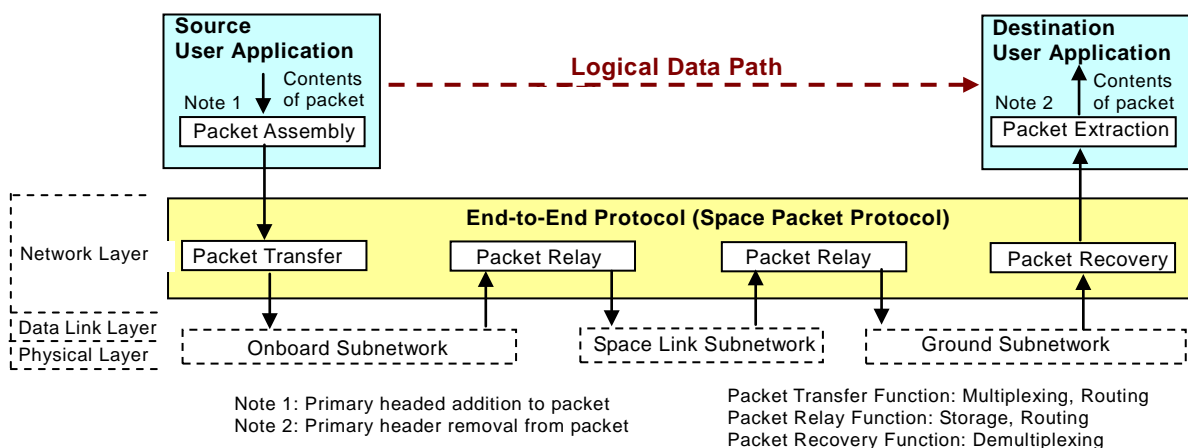

Figure 5.6-1 Space Packet Service

6. VERIFICATION REQUIREMENTS

6.1 Verification types and purpose

It is a matter of course to verify that the fabricated product conforms to the required specifications (quality verification); here, a compatibility test to verify as a communication system is specified.

As shown in Table 6.1-1, the compatibility test includes three types.

Table 6.1-1 Verification of **Communication** System

Test name	Purpose	Remarks
Subsystem/Payload Compatibility Test	In addition to verifying the onboard data bus protocol, verify the compatibility of the subsystems/payload with the various databases of the operation control system.	
RF Compatibility Test	Verify the compatibility of the physical interfaces between the ground and spacecraft.	
End-to-end Test	Data through test	

6.2 Subsystem/payload compatibility test

- (1) The test system is shown in Figure 6.2-1.
- (2) Verify the compatibility of the subsystem/payload with the onboard subnetwork protocol and the upper protocol (for operation) of the spacecraft operation control system (shown by the arrows in Figure 6.2-1(a)), according to the test configuration example in Figure 6.2-1(b).
- (3) As a general rule, this test shall be done before mounting the subsystem or payload on the spacecraft.

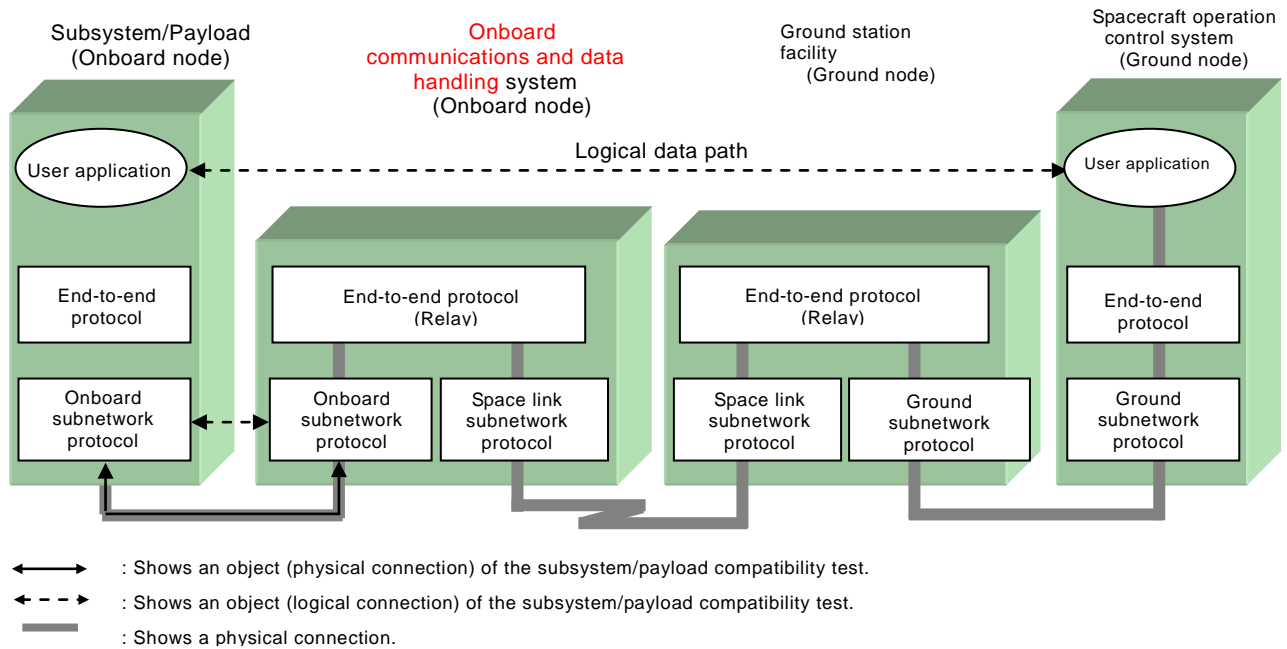

(a) Protocol Configuration and Object of Subsystem/Payload Compatibility Test

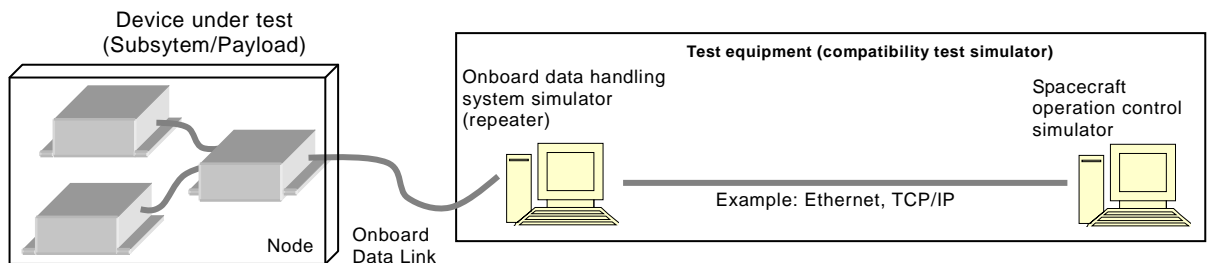

(b) Test Configuration Example

Figure 6.2-1 Subsystem/Payload Compatibility Test

6.3 RF compatibility test

- (1) The test system is shown in Figure 6.3-1.
- (2) The object of the test is the physical layer (solid arrow in Figure 6.3-1) of the space link subnetwork protocol. Include the data link layer if necessary (dashed arrow in Figure 6.3-1).
- (3) Coordinate the test method and test schedule with the ground station which uses the communications.

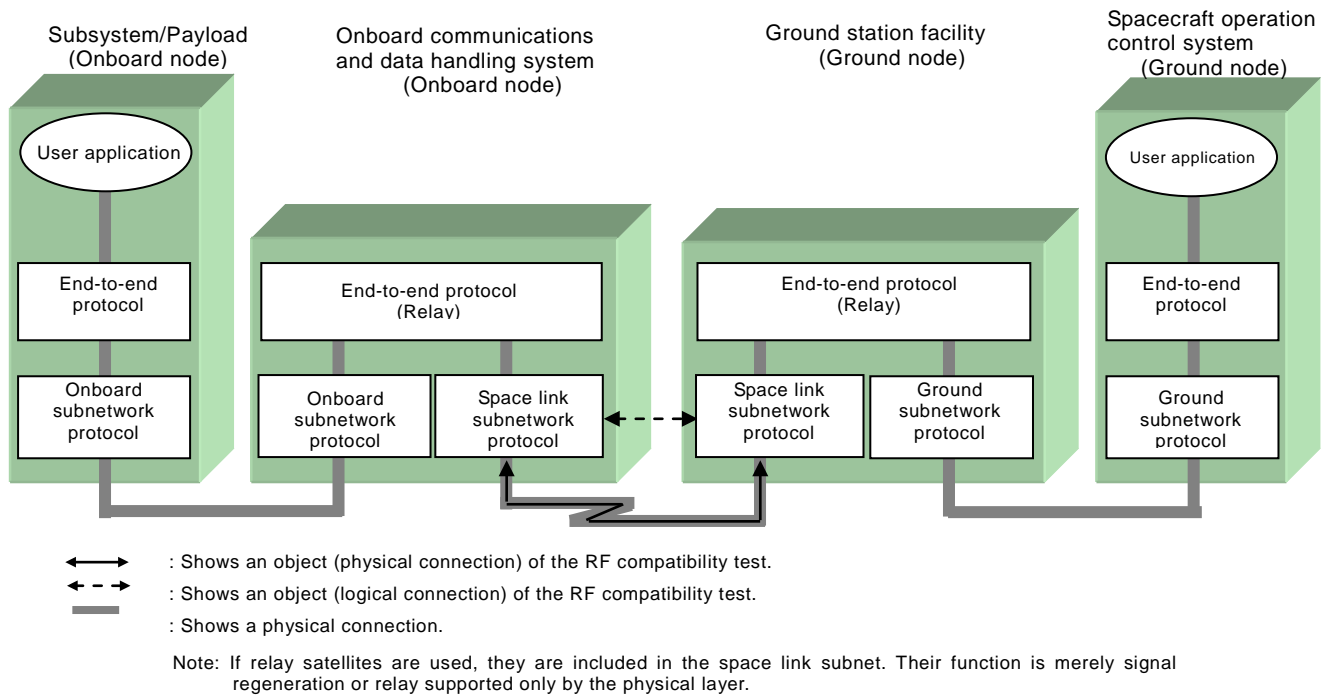

Figure 6.3-1 Protocol configuration and object of RF compatibility test

6.4 End-to-end test

- (1) The test system is shown in 6.4-1.
- (2) This is a data through test (physical connection confirmation test) between the spacecraft and spacecraft operation control system. (Figure 6.4-1)
- (3) This test shall be conducted before the launch of the spacecraft.

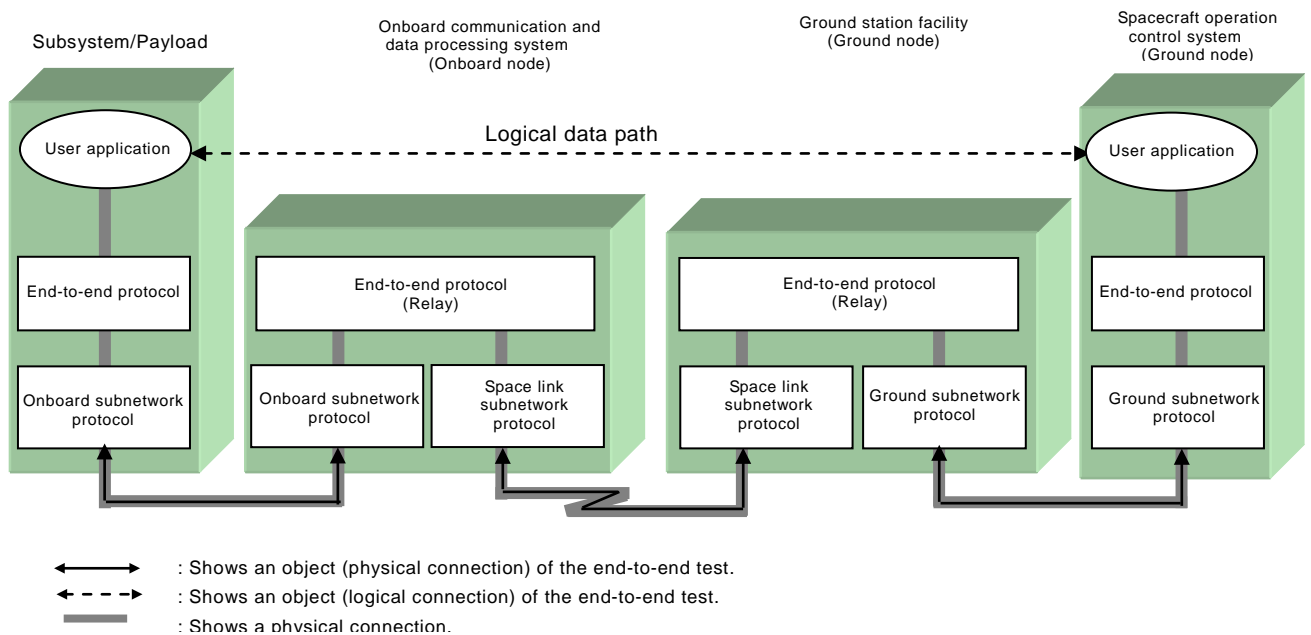

Figure 6.4-1 Protocol Configuration and End-to-end Test